

High Speed Direct Drive Upblast Food Truck Exhaust Fan

EADU50HFT

FEATURES:

- ROOF MOUNTED FANS
- RESTAURANT MODEL
- UL705
- VARIABLE SPEED CONTROL
- INTERNAL WIRING
- WEATHERPROOF DISCONNECT
- THERMAL OVERLOAD PROTECTION (SINGLE PHASE)
- HIGH HEAT OPERATION 300°F (149°C)

NORMAL TEMPERATURE TEST

EXHAUST FAN MUST OPERATE CONTINUOUSLY WHILE EXHAUSTING AIR AT 300°F (149°C) UNTIL ALL FAN PARTS HAVE REACHED THERMAL EQUILIBRIUM, AND WITHOUT ANY DETERIORATING EFFECTS TO THE FAN WHICH WOULD CAUSE UNSAFE OPERATION.

OPTIONS

LOW PROFILE OPTION - 50.
WALL MOUNT CONSTRUCTION FOR FAN
WALLMOUNT 20.5" SQ. X 2"

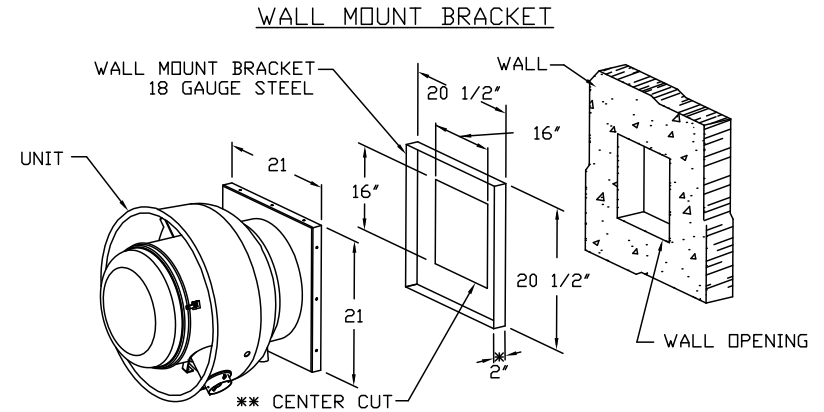
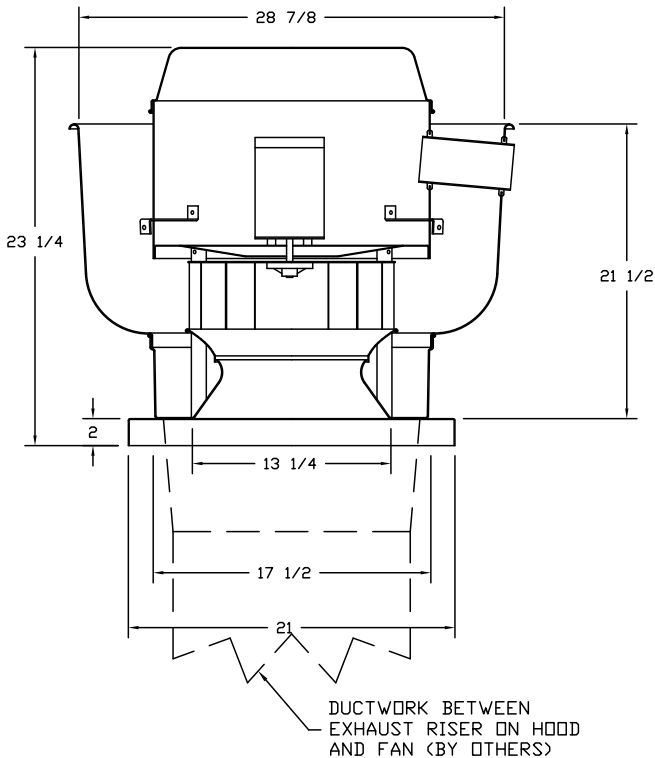

- WALL BRACKET FITS INTO BASE OF FAN
- SELF DRILLING SCREWS SHOULD BE USED FOR UNIT ATTACHMENT TO WALL MOUNT BRACKET
- * DIMENSION = 5" WHEN USED WITH DAMPER
- ** CENTERED IN WALL MOUNT